

BÖLLHOFF

RIVCLINCH®

Metal joining without fasteners



RIVCLINCH® – Metal joining without fasteners

What is clinching?

The clinching process is a method of assembling sheet metal without welding or fasteners. With this joining technique, metal parts are deformed locally without the use of any consumables.

It creates an interlocking of two or more metal layers. Painted or coated metal sheets can also be joined by this method without damaging the surface.

The RIVCLINCH® technology is a cost-effective, environmentally friendly method of joining steel and stainless steel sheets, as well as aluminum and/or non-ferrous metals.

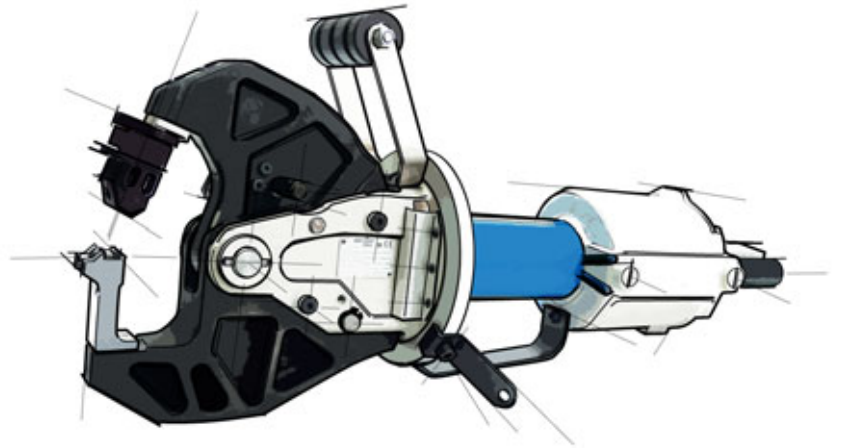

The joining technology

Deformation of the sheets by compression between punch and die:

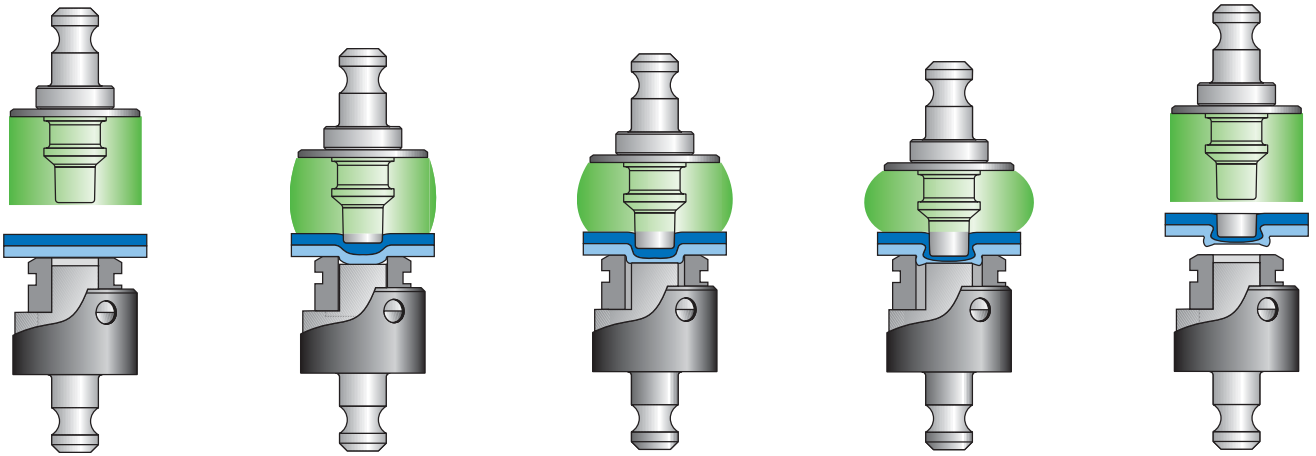

- 1) After being placed, the materials to be joined are firstly forced into the die with the punch.
- 2) As soon as the lowest material is resting on the die anvil, it starts flowing sideways under the pressure being exerted by the punch.
The blades are pushed outwards.
- 3) The punch is then returned to its starting position by the operator or by a pneumatic timer.
- 4) The metal sheets are now joined and can be removed. The blades are pulled back together by a spring.
- 5) The result is a resistant clinch joint.

Advantage at a glance

Our comprehensive hand tools and modular systems provide you with the possibility to use clinching technology in your business with moderate investment costs.

- **Short payback** thanks to high productivity, long lasting tooling, very low energy consumption and the absence of any consumables
- **Plug and play systems:** light weight and modular equipment for manual or robotic production
- **Friendly working environment:** No sparks, no fumes, no heating, no cooling, no solvent

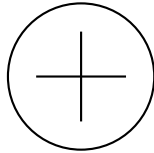

Economic

- No consumable items
- Very low power consumption
- No cooling or electrical installation needed
- Short cycle times (under 1 second)
- Low maintenance cost
- No specific skills required

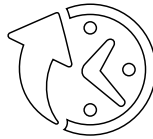

Efficient

- Very good strength and joint reproducibility
- No risk of corrosion
- Air tightness
- No damage to coating and no burn off
- Interim layers or film or adhesive can be incorporated in most case
- No thermal load on joining zone



Ecological

- Low energy use
- No fumes, no sparks, no thermal damage
- Quiet, simple and fast
- No pre/post treatment required, e.g. no pre-cleaning or subsequent removal of spray deposits around the joint

Optimum joints are no coincidence

We are the partner for your projects – from the very first concept to the final realization:

- Up-to-date 3D CAD systems allow customer-specific designs
- Sampling for your components with competent application engineering
- Manufacturing, assembly, commissioning as well as training of your employees
- Our maintenance, repair and service personnel makes your production a reliable process



Joining technologies – A comparison

	Clinching	Self-pierce riveting	Riveting	Screwing	Spot welding	Adhesion
Corrosion on coated material	low	low	low	low	high	none
Changes in structure and strength at the joining location	none	none	none	none	yes	none
Dynamic strength	very good	very good	suboptimal	suboptimal	suboptimal	good
Crash resistance	suboptimal	very good	suboptimal	suboptimal	suboptimal	good
Static strength: 1. Shear tension 2. Pull-out tension	good good	very good very good	very good very good	very good very good	very good very good	good good
Required fasteners	none	self-pierce rivet	rivet	screws nuts washers thread	none	adhesive
Additional process steps	none	feeding	feeding, caulking	feeding, screwing	coated surfaces	pressing curing
Costs per joint	very low	low	very high	very high	high	high
Energy input	low	low	high	high	very high	very high
Economic efficiency	very good	good	poor	poor	suboptimal	suboptimal
Environmental friendliness at the workplace	very good	very good	good	good	poor	very poor
Handling	very easy	easy	easy	easy	easy	complex
Reproducibility	very good	very good	good	good	satisfactory	good
Dependence of resulting joint on surface condition	low	none	none	low	high	very high
Pre-operation	none	none	drilling	drilling	washing pickling	washing pickling

Joinable materials

Typical materials which can be clinched include:

- Low carbon and micro-alloyed steels
- Zinc-coated, organic coated and pre-painted steels
- Stainless steels
- Lightweight materials, such as ductile aluminium alloys

Dissimilar material combinations can also be clinched, for example steel to aluminium.

	Standard	Special
Material of sheets	Aluminium Copper Mild Steel Stainless Steel	Up to Grade 304 (Tensile strength 500 MPa)
Total thickness of sheets (T)	1 to 6 mm	10 mm steel 18 mm copper
Cycle time	0.4 to 1.2 sec	–
Diameter of die (D)	3 to 8 mm	1 to 10 mm
Shear strength	1 to 8 kN	–
Joining Force (F)	25 to 75 kN	100 kN (single tool) 300 kN (multiple tooling)

RIVCLINCH® joint point geometry

The heart of our expertise stands in the clinching joint.

Depending on the clinching tool selected, the resulting joint will be either round or rectangular.

Round joining point (SR)

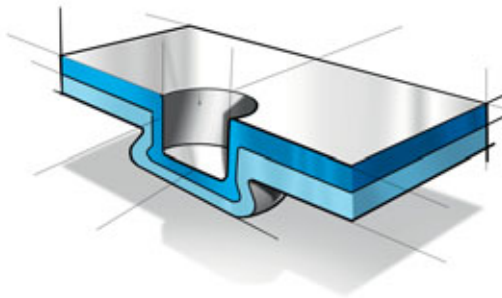

- The SR round joint without cutting through the material, is just a deformation.
- This joint is water and gas tight. Consequently it protects the coating better and provides high corrosion and fatigue resistance.
- This joint is also aesthetically pleasing.

Rectangular joining point (ST)

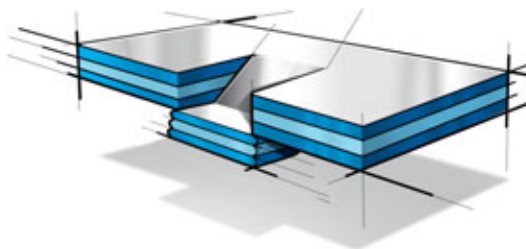

- The ST rectangular clinch joint is the product of a combined cutting and deforming process.
- It is primarily suited to multi-layer (up to 5), harder metals such as stainless steel and wider range of thicknesses.

Quality check of the RIVCLINCH® joint

Quality surveillance

For clinching, there is a causal relationship between joint quality and the geometry of the joining element.

It is therefore possible to estimate the quality of the joint from a visual evaluation of the joining element and by measuring geometric parameters.

The tool kits

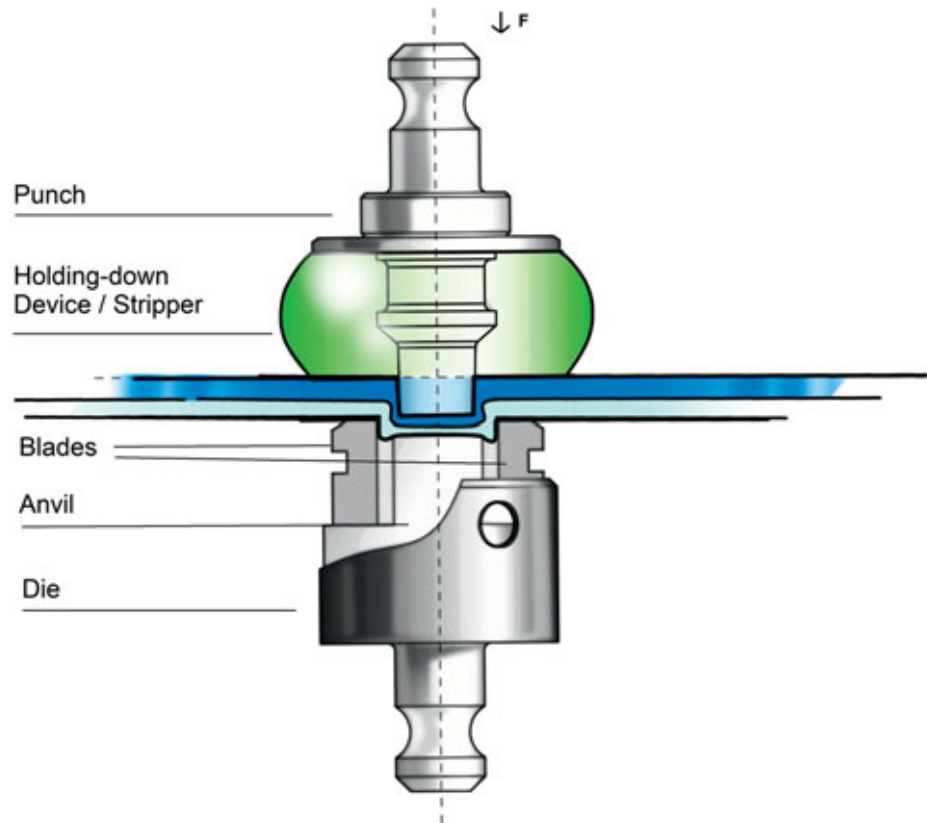

Toolkit selection

The central component of the RIVCLINCH® joining system is the tooling, or “tool kit”.

Selecting the tooling is the first step involved when studying a new clinching application, since it will determine the pressing force and therefore the size of the clinching force unit and work head.

Our RIVCLINCH® tools are available for round clinch joints (SR) with nominal diameters of 3, 4, 5, 6, 7, 8 and 10 mm and rectangular point joints (ST) with nominal widths of 3, 4, 4.3, 5 and 6 mm. Non standard dimensions are generally available from diameters of 1.0 to 10 mm.

The choice of tooling is depending of the sheets to be clinched

1. Material (mild steel, stainless steel, aluminium, copper, etc.)
2. Thicknesses
3. Number of layers and order between punch and die

With all this information brought together, the machine can be suited to the clients application.



A multiple tool holder can be used to integrate tool sets into corresponding RIVCLINCH® portable units, modular work heads or a press.

Small edges (FS series – Air to oil driven)

Ideal for cabinets, vending machines, freezers, ventilation and many other domains Air to oil driven with booster. Short stroke, light weight and fast tools for joining edges and flat panels over short depths.

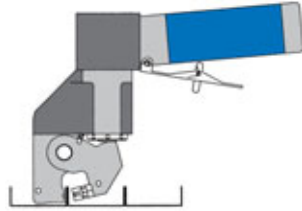

RC 0201 FS Wall structure

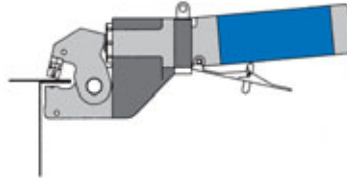

RC 0201 FS Edge of cabinet

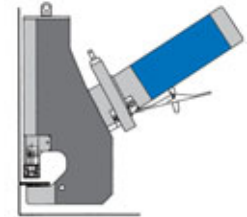

RC 0501 FS Cabinet wall

Medium range (IP Series – Fully pneumatic)

Medium range jaw opening, fully air driven. For the assembly of profiles or folded edges which require a larger jaw opening. The quick and safe closing jaw of the IP models is a perfect solution for such products.

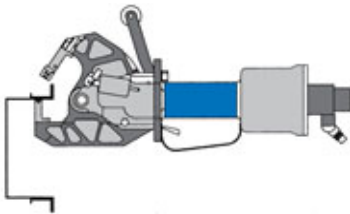

RC 0404 IP Boxes and ducts

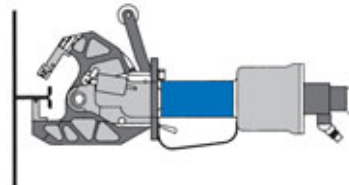

RC 0404 IP Boxes and ducts

Large structures (PASS Series)

Various C'frame dimensions and geometries can be supplied using the same force unit. It is quite often necessary to set the clinch joint further away from the edge, or for passing over steps. Working from the top of a product or accessing a more confined box is often necessary. This type of machine is the best solution in this case.

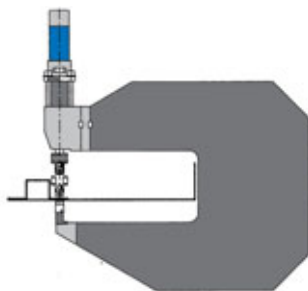

RC P50 PASS Large Frame

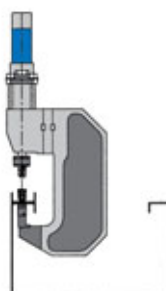

RC P50 PASS Housing

RIVCLINCH® PNEUMATIC (IP-Series)

100% pneumatic tools with quick closing jaws.

A range of autonomous, lightweight and ergonomic pneumatic portable tools, particularly for the assembly of large parts. The automatic opening/closing system of the jaw by pneumatic cylinder guarantees an optimal safety of the operator. Its installation is very easy: just connect the machine to the compressed air network at 6 Bar using the quick coupling. There is no hydraulic and electric hose.



Technical data	RC 0201 IP	RC 0404 IP V2 (90°)	RC 0404 IP V3	RC 0706 IP
Total weight	2.9 kg	6.2 kg	6.3 kg – 13 lb	24 kg – 53 lb
Cycle time	0.3 – 0.7 s	0.5 – 0.9 s	0.5 – 0.9 s	1 – 1.2 s
Joining force at 6 bar	25 kN	35 kN	35 kN	50 kN
Depth of jaws	20 mm	45 mm	45 mm	70 mm
Jaws opening	NA	34 mm	34 mm	60 mm
Max. total sheet thickness, mild steel	2.5 mm	3.0 mm	3.0 mm	4.5 mm
Max. total sheet thickness, stainless steel	1.8 mm	2.5 mm	2.5 mm	3 mm

RIVCLINCH® HYDRAULIC (FS-Series)

Booster driven: light and fast hand tools.

Light weight and fast tools for joining edges and flat panels. Convenient for cabinets, refrigerated window displays, vending machines, freezers, ventilation and many other sectors.



Technical data	RC 0201 FS
Workhead weight	2 kg
Cycle time	0.4 – 0.8 s
Joining force at 6 bar	25 kN
Jaw opening	7 mm
Depth o jaws	16 mm
Noze height	25 mm
Total sheet thickness: Mild steel	2.5 mm
Total sheet thickness: Stainless steel	1.8 mm



RIVCLINCH® 4006 P50 PASS

Cost effective, multi-purpose clenching machine

A wide range of patented RIVCLINCH® tool are available for this machine, allowing to join thin sheet as well as thick material up to 6 mm total thickness and large opening allowing most combination of materials such as mild steel, aluminium and stainless steel.

Due to its long and thin lower arm, this unit is perfect to join metal parts for a large number of applications in the Building sector, HVAC, Appliances, Vehicles, Furniture, Electric, Roofing and many other sectors.

Technical data	
Weight of workhead	230 kg
Cycle time	1.0 – 1.2 sec
Joining force at 6 bar	50 kN
Work Stroke	8 mm
Total opening	60 mm
Depth	400 mm
Max. total sheet thickness: Mild steel	4.5 mm
Stainless steel	3 mm
Aluminium	5 mm

The Passive Approach Stroke System (PASS) for optimum safety in standard equipment.

The pre-stroke is pneumatic and can be activated independently of the work stroke, for a safe long approach stroke and an easy tool positioning.



RIVSTITCH® 0101 SF

Ideal for pre-coated, multilayer assemblies of thin sheet metals. The low weight, low noise and the absence of recoil makes the RIVSTITCH® 0101 SF a very user-friendly and productive machine.

This very versatile tool can now be equipped with stitch folding or pinching functions.

Technical data	
Weight of workhead	2.4 kg
Cycle time	0.6 s
Max. total thickness, mild steel	1.8 mm
Max. total thickness, stainless steel	1.2 mm

Stich folding:

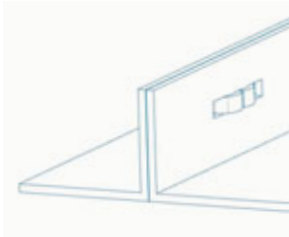

In stitch folding, material tabs are cut out by punches. These tabs are then folded back and compressed.

Pinching:



Wrapped layers can be pinched together. Materials are only deformed without any cut-out.



Our clinching solutions can be portable, stand alone, automatic or robot mounted also with process control.

With more than forty years of experience, Bollhoff Attexor SA engineering team will assist you in the development of your individual process solution.

Modular C-FRAMES

A range of powerful workheads, portable or stationary operating by compressed air booster.

We offer a wide range of C-frames dimensions with a depth of up to 1100 mm to suit applications in any industry and in the automotive sector.

Our C-frames are equipped with the PASS system (Passive Approach Stroke System). In addition to the safety aspect, the PASS facilitates the positioning of the tool at the clinch joint location and reduces cycle time when performing multiple series assemblies.

This makes it possible to drive several working heads by means of a single pneumatic amplifier activated only briefly, at the precise moment of clinching.

All modular machines with a clamping force of 35 to 300 kN can be equipped with the PASS option.

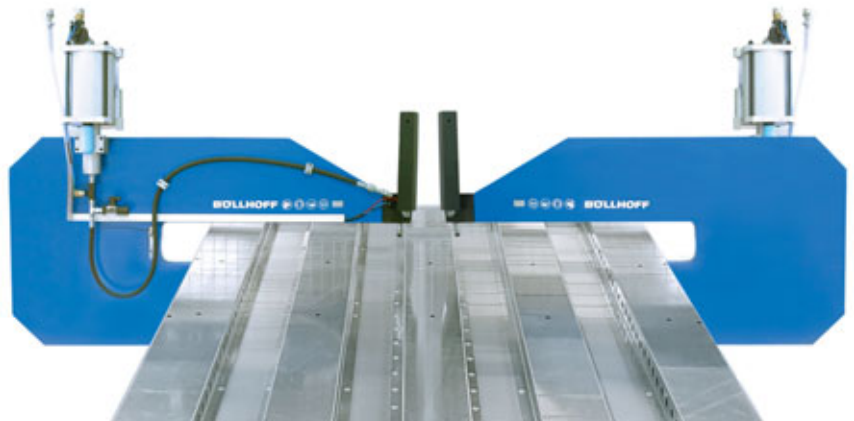

Modular systems for semi-automatic / fully automatic solutions

We also offer tailor-made solutions for semi or fully automated lines. Contact your local partner.

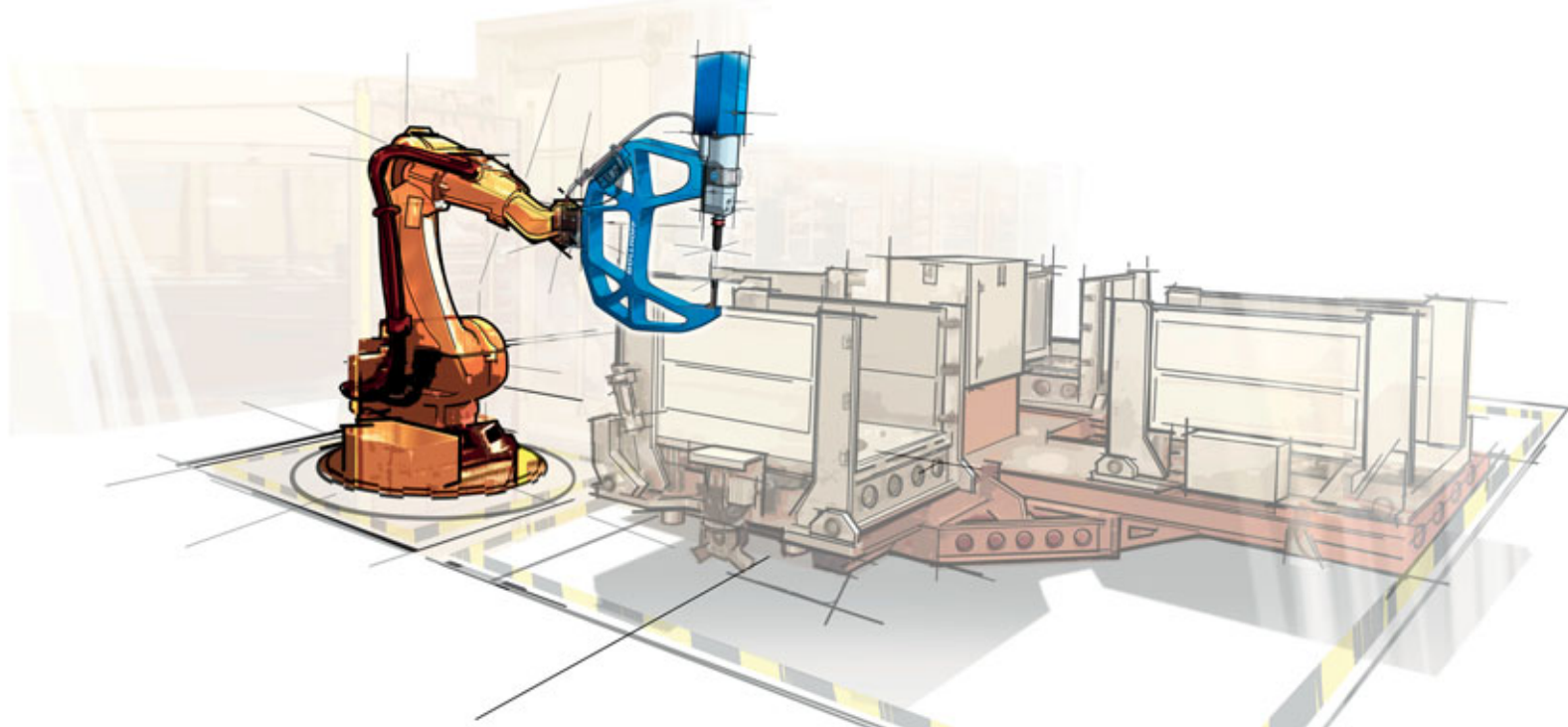

Applications

Our handtools or modular solutions meet the high demands of the industries in many fields of applications.



Building Technology

- Garage doors
- Exterior doors / interior doors
- Elevators
- Solar panels
- Solar Thermal
- Cable trays
- Lighting
- Scaffolding / Ladders
- Busbar

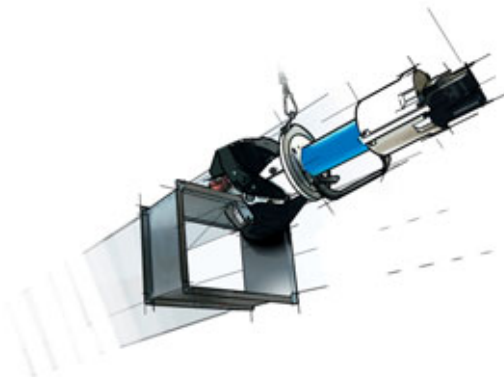

Heating, Ventilation, Air Conditioning

- Air ducts
- Air filters
- Heat exchangers
- Radiators
- Convectors
- Boilers
- Pocket filters



Domestic appliances (white goods)

- Washing machines
- Tumble Dryers
- Refrigerators
- Ovens / cookers / range cookers
- Kitchen
- Switch contacts

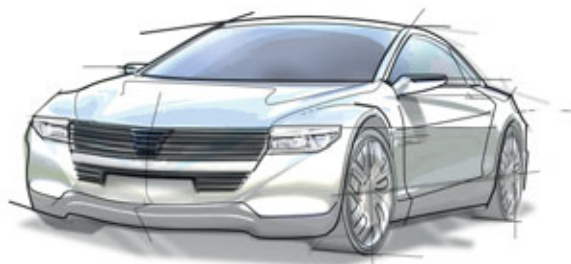

Automotive industry

- Battery box
- Battery heat exchanger
- Thermal insulation
- Body area:
 - Frontend and rearend
 - Doors
 - Roof frame
 - Top compartment
 - Wheel arch, etc.
- Airbag
- Busbar

Installation of a portable clinching machine

The air supply must be dry, filtered and regulated, with a minimum size of 1/2" for ensuring the shortest possible cycle time. All the RIVCLINCH® systems are designed for operation without lubricator on the air preparation unit.

- Pivoting or 2 axis rail
- Separate fixations for booster and balancer
- Vertical suspension mandatory for all work area
- Security cables on all items

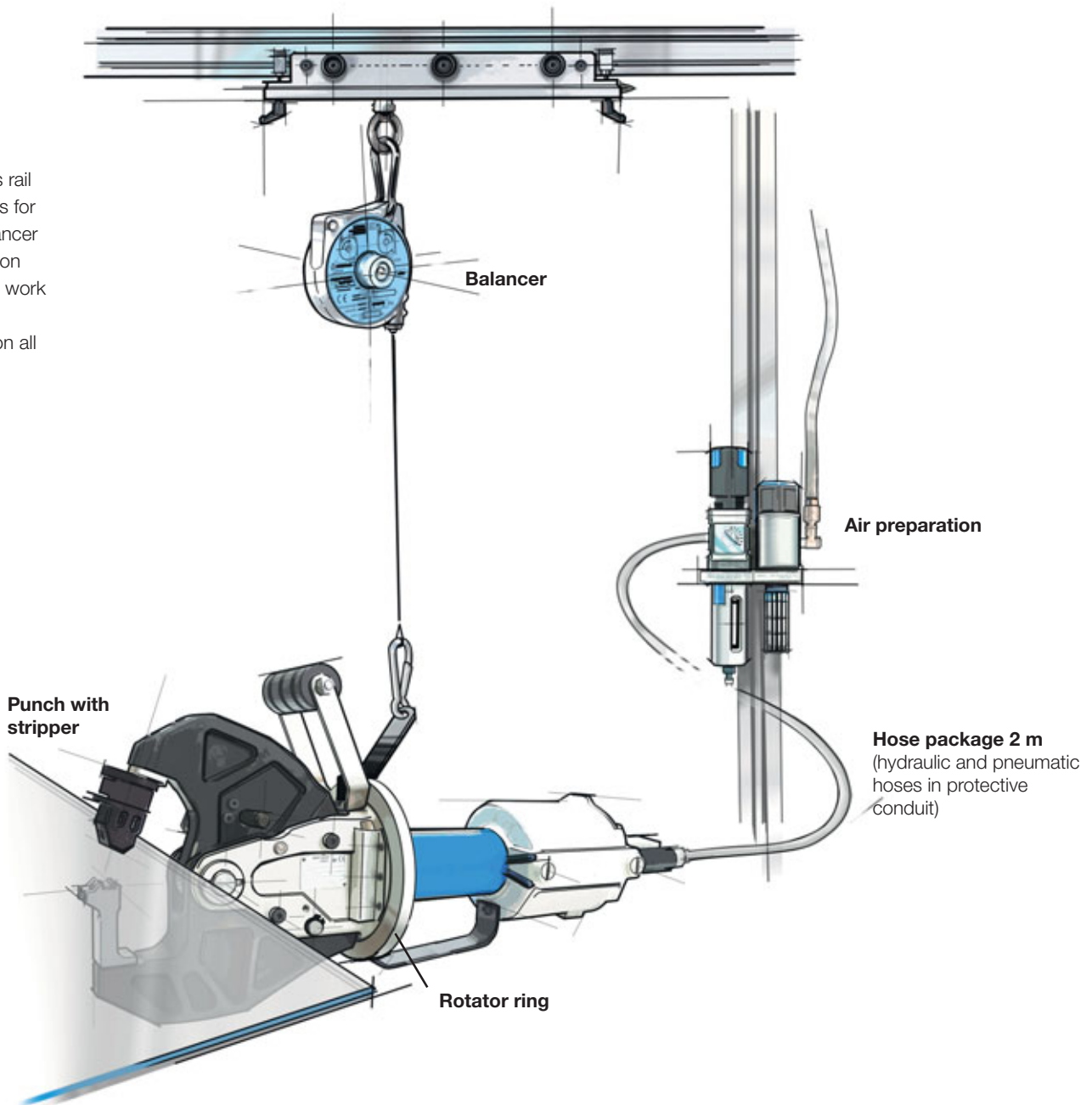

Workhead

Well balanced in all positions by means of a gyroscopic suspension, ball bearing mounted for easy handling. The rotating axis is placed around the handle and the swivel hydraulic connection, in order to facilitate the work head manipulation with one hand and without effort.

Installation of a modular clinching solution

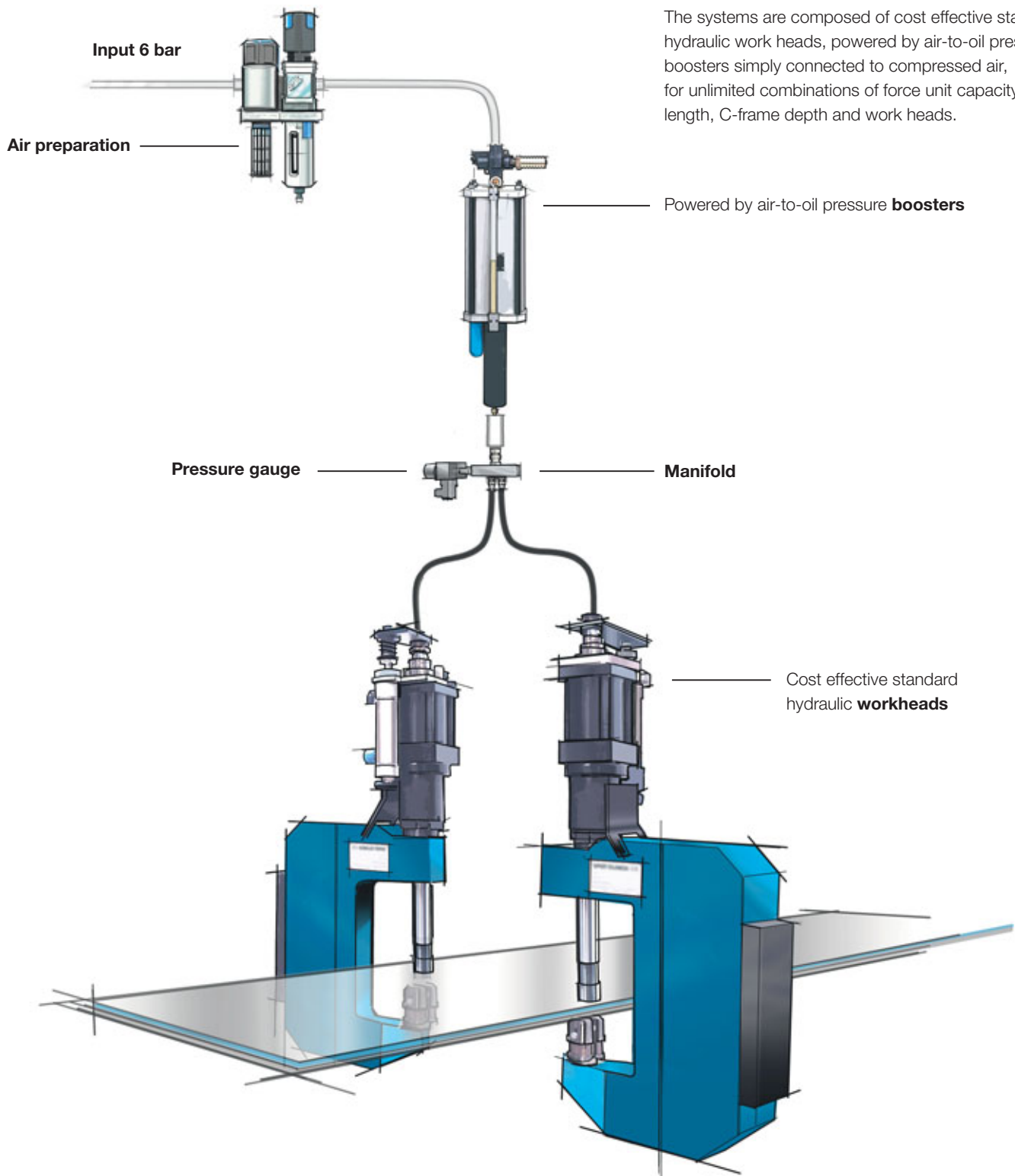

The systems are composed of cost effective standard hydraulic work heads, powered by air-to-oil pressure boosters simply connected to compressed air, for unlimited combinations of force unit capacity, stroke length, C-frame depth and work heads.

Powered by air-to-oil pressure **boosters**

Pressure gauge

Manifold

Cost effective standard hydraulic **workheads**

Sliding support

With many of our hand tools, the workhead without handle can also be used in automated production.



Booster

The booster is a pressure intensifier that increases conventional compressed air of 6 bar by the factor 60 so that an operating pressure of 360 bar is achieved on the hydraulic side.

Advantages over conventional hydraulic power packs:

- Closed, leak-proof hydraulic circuit
- No power consumption during idle time
- Particularly low-maintenance and easy-to-handle -power source
- High speed and therefore short cycle times
- Simple mere pneumatic control
- Just connect compressed air and the RIVCLINCH® system is ready to operate

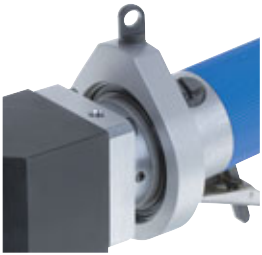

Rotator ring

Increased movability for joining in every position.
Ergonomic tool handling.



Balancer (optional)

To make life even easier for you, there is an adapted balancer for every RIVCLINCH® tool to compensate the tool weight.

Standard balancers:

From 2 – 3 kg, (1.6 m cable length) up to 22 – 25 kg, (2 m cable length). Above 25 kg on request



Compressed air conditioner (optional)

The easiest and most common way to operate RIVCLINCH® systems is the drive with conventional compressed air of 6 bar.

To control the operating pressure and for separation of water which can accumulate in the line system of your compressed-air system, a maintenance unit with water separator and oiler must be installed.

Required compressed air can be classified as follows:

- **Humidity:** ISO 8573-1 class 4 -> water dew point + 3°C
- **Max. oil content:** ISO 8573-1 class 2 -> 0.1 mg/m³ compressed air



Parameters and control of the clinching point

Unlike spot welding, each clinching point can be controlled without destroying the assembly.

The RIVCLINCH® point can be easily controlled by measuring the residual thickness button (X or ST dimension) and the outside diameter.

These values are defined when choosing the tool set. They appear in each of our test reports. If these measured ratings are consistent, the good performance of the clinching point is guaranteed without having to perform destructive testing

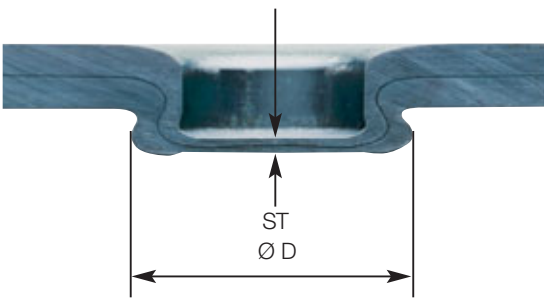

Process monitoring (optional)

It is also possible to check the quality of each clinching point through a process control box. The following faults can be detected:

- Missing part
- Materials that are too hard / too soft
- Punch or die break
- Loose of setting



Clinch cycle control OCC

- Only 1 x trigger impulse for a full clinch cycle
- No maloperation by worker due to too brief triggering
- Clinch process runs automatic
- Pneumatic pressure controlled (Pneumatic controlled pressure sensor)

BÖLLHOFF



Böllhoff Group

Innovative partner for joining technology with assembly and logistics solutions.

Find your local partner at www.boellhoff.com or contact us at sales_bax@bollhoff.com.

Passion for successful joining.

BOLLHOFF ATTEXOR SA | ZI Le Trési 9A | CH-1028 Préverenges | Switzerland
Tel.: +41 21 694 80 00 | Fax: +41 21 694 80 01 | sales_bax@bollhoff.com | www.bollhoff-attexor.com

Subject to technical change.
Reprinting, even in extract form, only permitted with express consent.
Observe protective note according to ISO 16016.